



Geotech
DRILLING

TRACK RIGS

Portable and powerful, to go just about anywhere.

► **2010 Geoprobe® 7822DT**

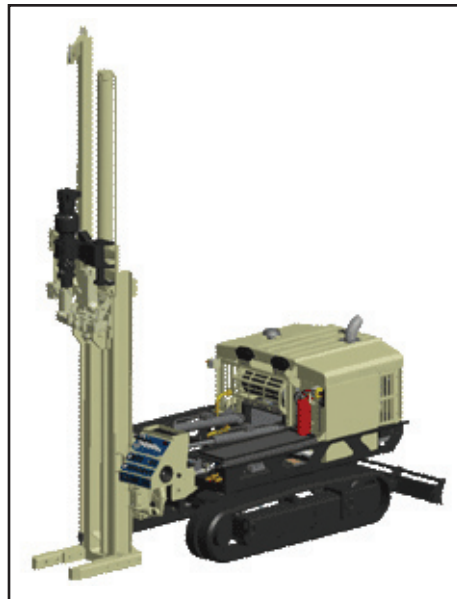

- 78" (1,981 mm) probe cylinder stroke
- 48,000 lb (214 kN) pullback
- New GH64 Hammer with Modular Percussion Power Cell and integrated two-speed, bidirectional rotation
- GA4000 Augerhead offers more torque and is integrated onto a redesigned swing-out mounting system
- Designed and built CE compliant
- Auxiliary hydraulic power ports
- Rear stabilizer with Geoprobe® Drop Rack System
- Oscillation provides for easy vertical positioning of the foot on unlevel terrain
- New mast and winch configuration provides better control and faster line speed
- Powered by a four-cylinder, 58 Hp, liquid-cooled Tier 3 compliant Kubota turbo diesel engine
- Dimensions: Height = 184"
Length = 133"
Width = 60"



GEOTECHNICAL



EXPLORATION



ENVIRONMENTAL



HYDROGEOLOGICAL



GEOTHERMAL



HEALTH & SAFETY



Geotech
DRILLING

1-888-228-1234 • Web: www.geotechdrilling.com